

Fassi F215A



FASSI

fassi.by



**МАКСИМАЛЬНЫЙ ГРУЗОВОЙ МОМЕНТ:
до 20,1 тм**

**МАКСИМАЛЬНЫЙ ВЫЛЕТ:
до 23,60 м**

- система безопасности
- система контроля устойчивости

F215A.0.21	20.08	6.30	1.80	400	33.5	30	45	120	2005	2445	870	2255
F215A.0.22	18.86	8.30	3.75	400	33.5	30	45	120	2180	2445	870	2255
F215A.0.23	18.14	10.40	5.75	400	33.5	30	45	120	2355	2445	870	2255
F215A.0.24	17.84	12.55	7.85	400	33.5	30	45	120	2505	2465	870	2255
F215A.0.25	17.53	14.65	9.85	400	33.5	30	45	120	2625	2480	985	2255

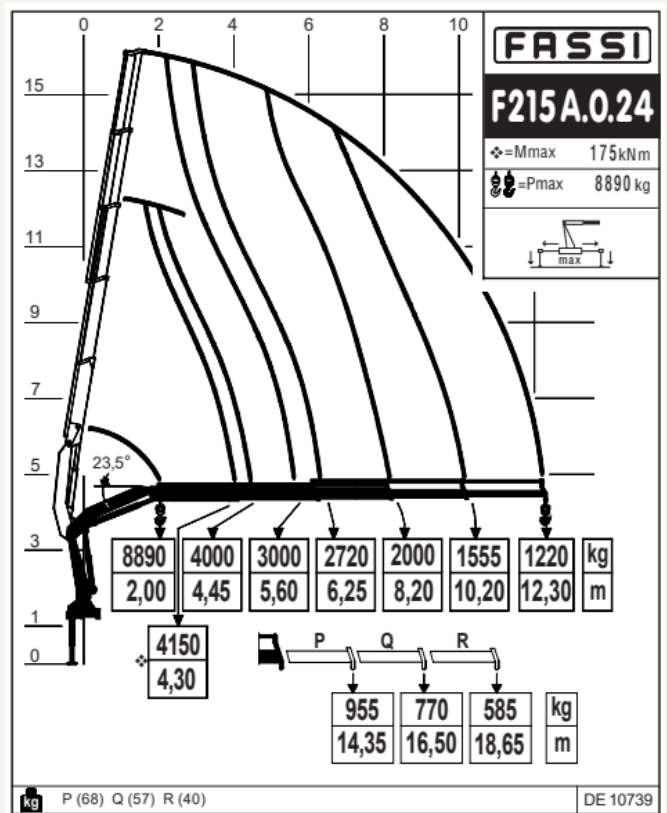
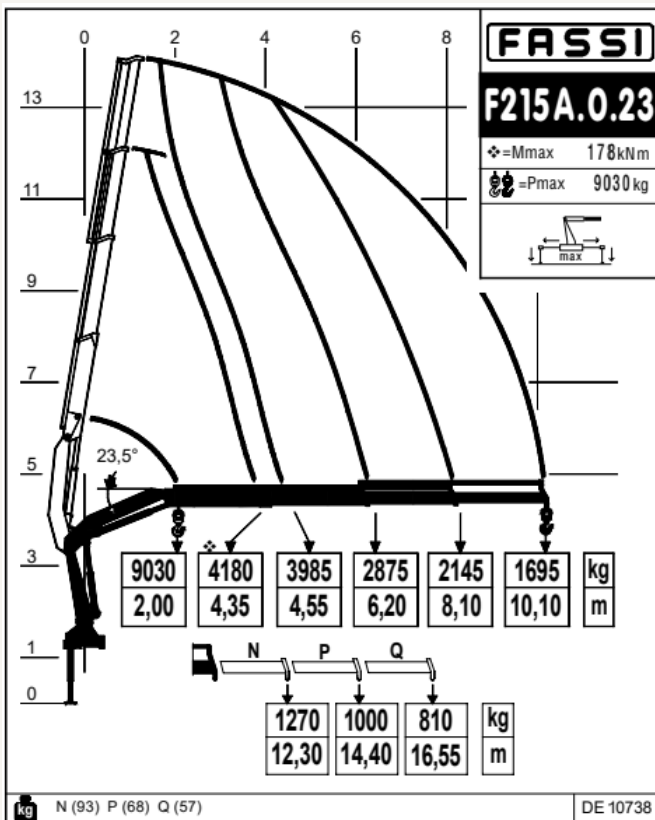
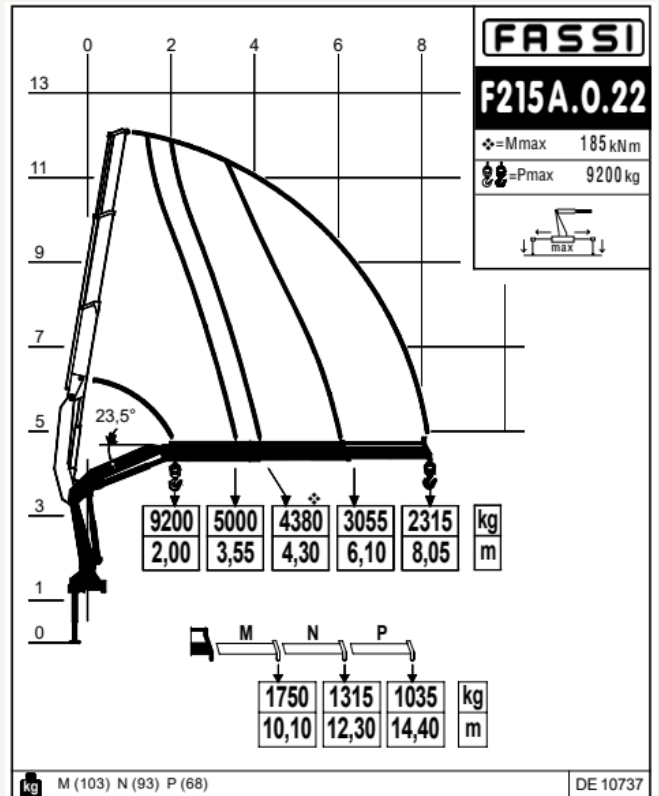
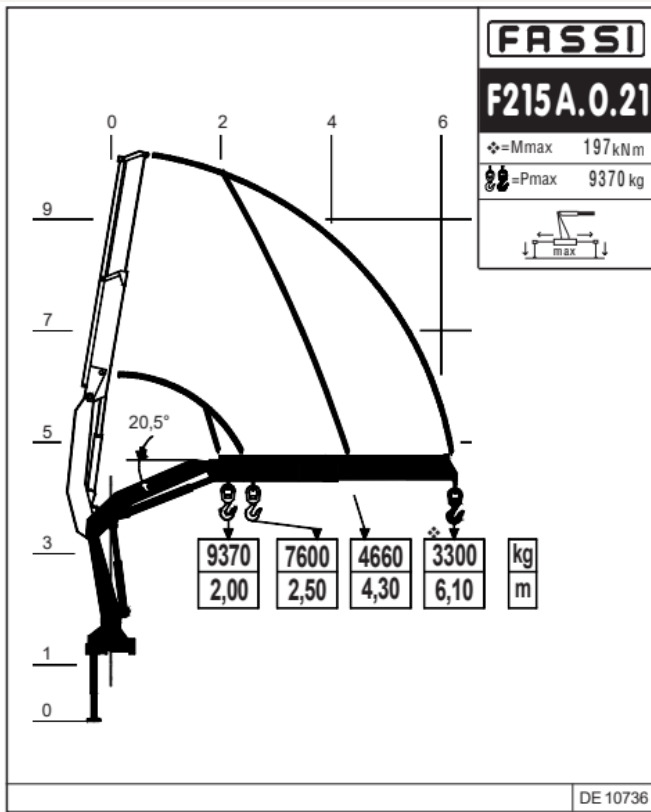

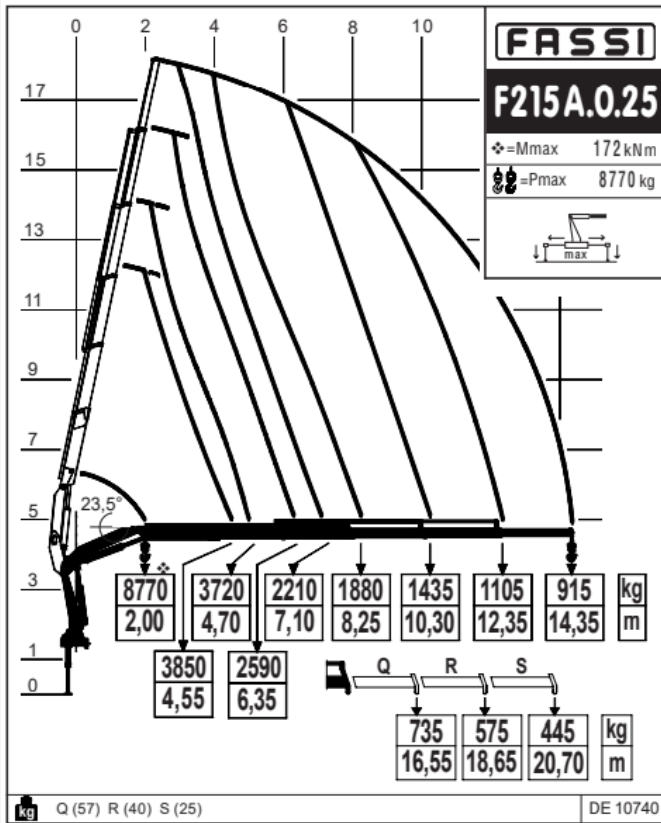

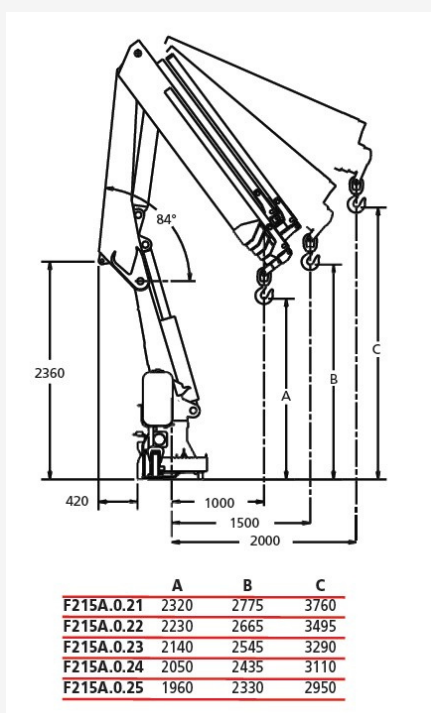
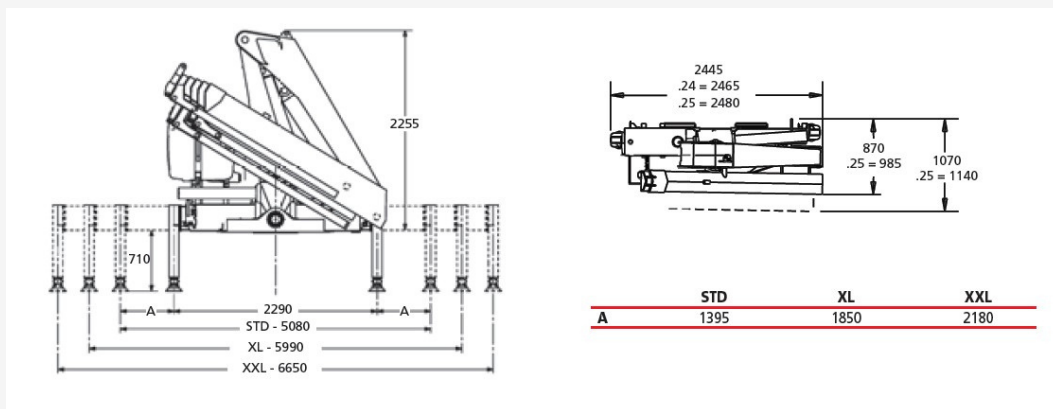

Тел.: +375 29 661 66 99, +375 33 661 66 99

Crane-Technologies@yandex.by

fassi.by