

Fassi F235A



FASSI

fassi.by



**МАКСИМАЛЬНЫЙ ГРУЗОВОЙ МОМЕНТ:
до 21,3 тм**

**МАКСИМАЛЬНЫЙ ВЫЛЕТ:
до 23,60 м**

- система безопасности
- система контроля устойчивости

F235A.0.21	21.20	6.30	1.80	400	31.7	32.0	45-65	120	2005	2445	870	2255
F235A.0.22	20.29	8.30	3.75	400	31.7	32.0	45-65	120	2180	2445	870	2255
F235A.0.23	19.67	10.40	5.75	400	31.7	32.0	45-65	120	2355	2445	870	2255
F235A.0.24	19.27	12.55	7.85	400	31.7	32.0	45-65	120	2505	2465	870	2255



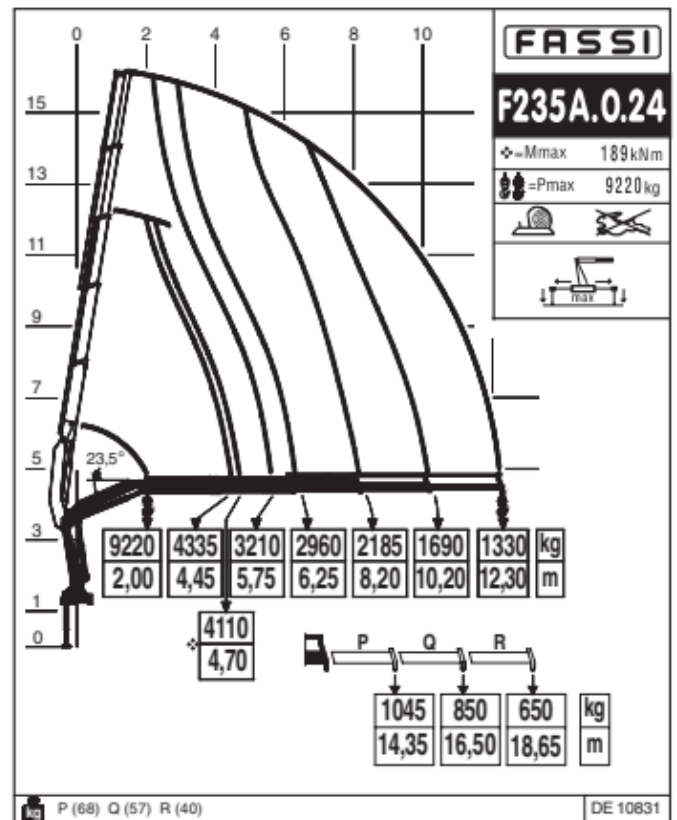
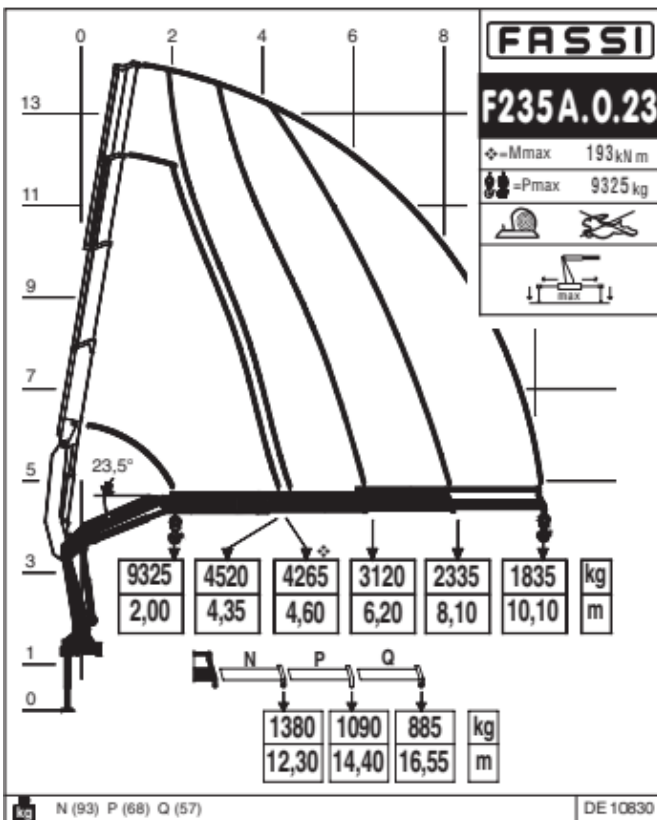
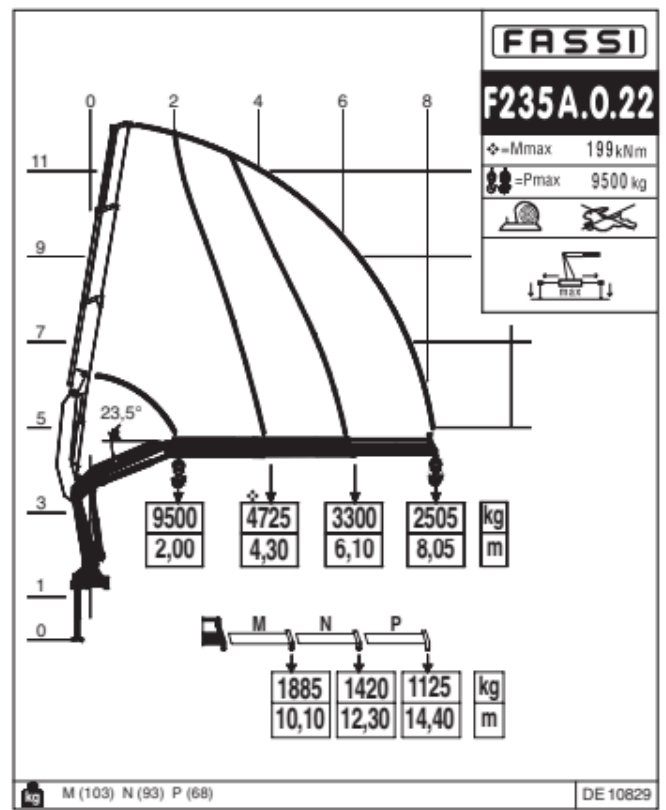
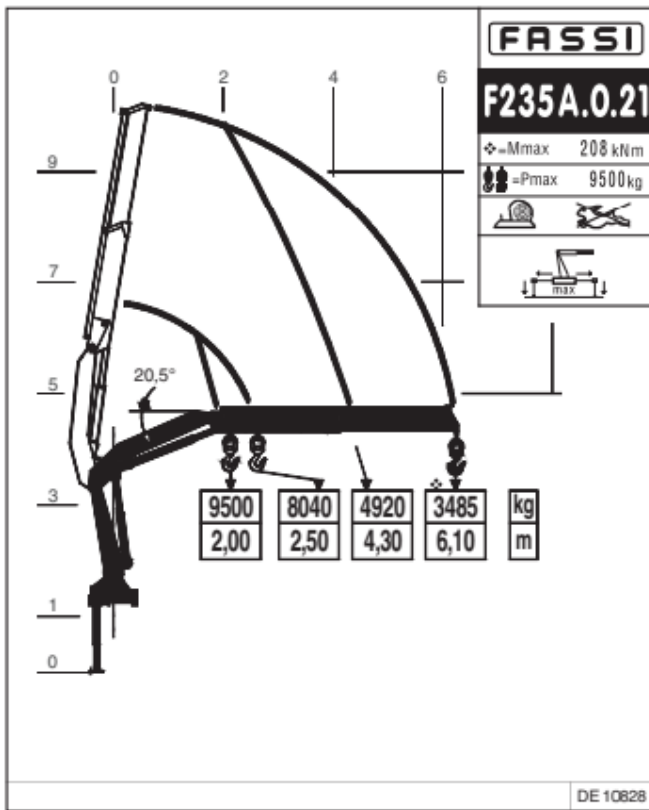

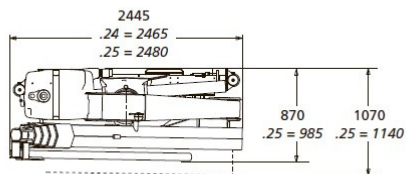
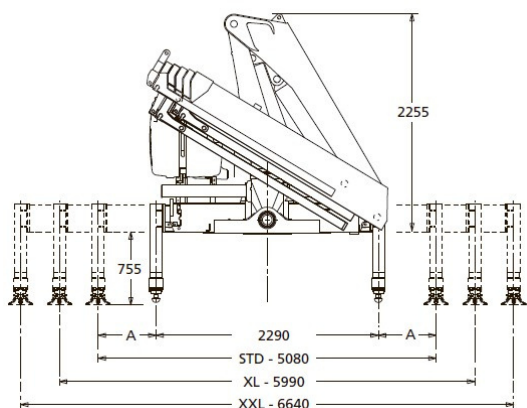

	STD	XL	XXL
A	1395	1850	2180

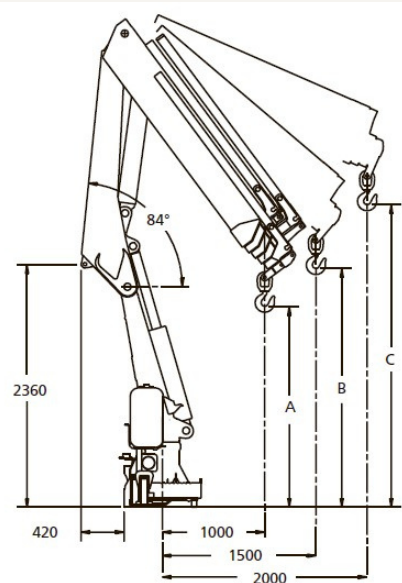

	A	B	c
F235A.0.21	2320	2775	3760
F235A.0.22	2230	2665	3495
F235A.0.23	2140	2545	3290
F235A.0.24	2050	2435	3110



Тел.: +375 29 661 66 99, +375 33 661 66 99

Crane-Technologies@yandex.by

fassi.by